



One-Door Worktop Refrigerator

MODEL #RIF-2D-SS

Every commercial kitchen deserves the coolest, sleekest, most convenient refrigeration solutions. The KoolMore Commercial Worktop Refrigerator is made of gleaming 430 type stainless steel and topped with generous worktop space, making it ideal for restaurants, hotels, cafeterias, and all commercial kitchen use.

CABINET CONSTRUCTION

Heavy duty all-stainless-steel construction includes corrosion-resistant 304 stainless steel interior and durable 430 stainless steel exterior.

Foamed-in-place CFC- and HCFC-free polyurethane insulation enhances the structural integrity of the cabinet and helps increase energy efficiency.

REFRIGERATION SYSTEM

Environmentally-safe R290 refrigerant. Bottom-mounted condensing unit positioned for easy maintenance.

“No stoop” lower shelf raises product to a higher level for easy access.

MODEL FEATURES

Preprogrammed digital controls feature auto-defrost function.

Shelf rails accommodate full size food pans for storage flexibility.

Interior back panel separates shelf and back wall to promote proper airflow.



Special Features

- Digital temperature controls
- Climate-friendly and cost-effective R290 refrigerant
- Convenient and spacious work surface area
- Stainless steel body
- Self-closing door with a stay-open feature for easy load
- Epoxy coated corrosion resistant adjustable shelf with 90 lbs. capacity
- Four casters with two breaks for increased mobility and easy cleaning
- Preprogrammed digital controls feature auto-defrost
- Removable door gasket

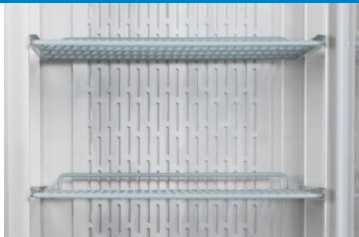



27 In. One-Door Worktop Refrigerator With 3.5 In. Backsplash – 6.3 Cu Ft



TECHNICAL DATA

Dimensions

Exterior Dimensions	27"W x 29.50"D x 38.75"H
Interior Dimensions	22.25"W x 22.88"D x 23.5"H
Net Volume	6.3 cu. ft.
Net Weight	159 lb.
Packaging Dimensions	27"W x 29.5"D x 38.75"H

Cooling

Preset Temperature Range	33° F 40° F
Refrigerant	R290
Max. Ambient Temperature	90° F
Defrosting	Automatic
Temperature Controller	Digital
Horsepower	1/6

Construction

Exterior Material	430 Stainless Steel
Interior Material	430 Stainless Steel
Insulation Material	Foamed-In-Place Polyurethane
Shelf Material	Epoxy-Coated Steel
Shelf Load Capacity	90lb.

Electrical

Voltage	115
Amps	1.9
Hz	60
Phase	1
Plug Type	NEMA 5-15P



Parts & Labor



Compressor



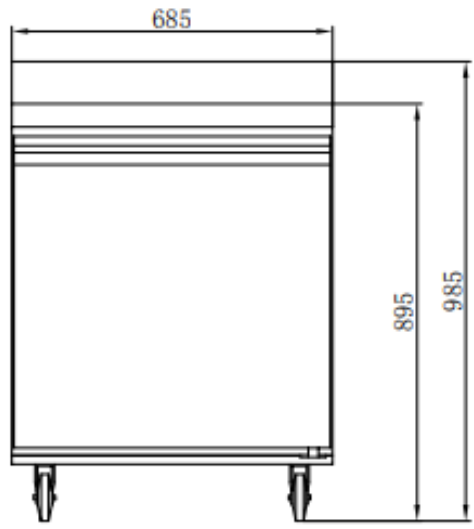

ELEVATION

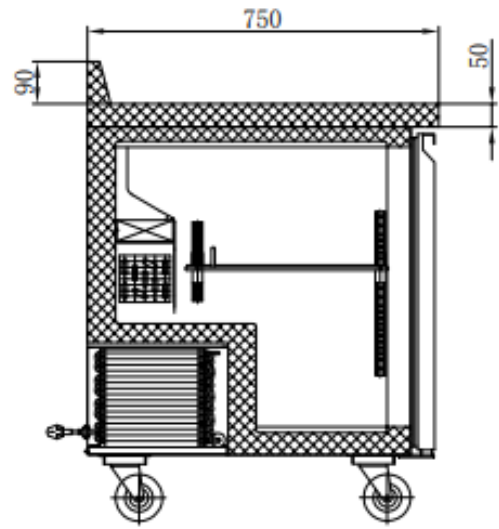

SECTION VIEW

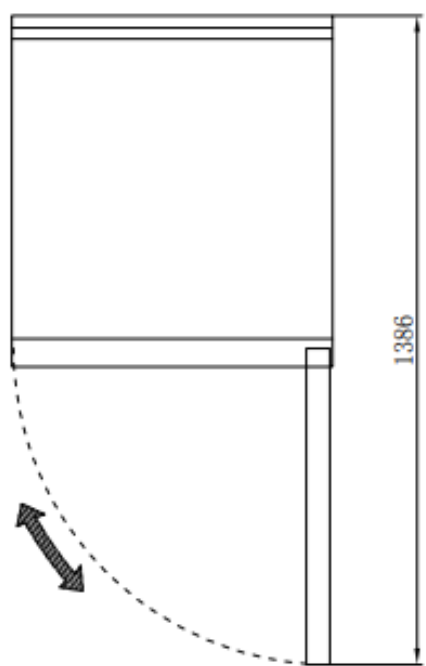

PLAN